

© 1968 BY AMP INCORPORATED. ALL RIGHTS RESERVED. AMP PRODUCTS COVERED BY PATENTS AND/OR PATENTS PENDING.

NUMBER 52007

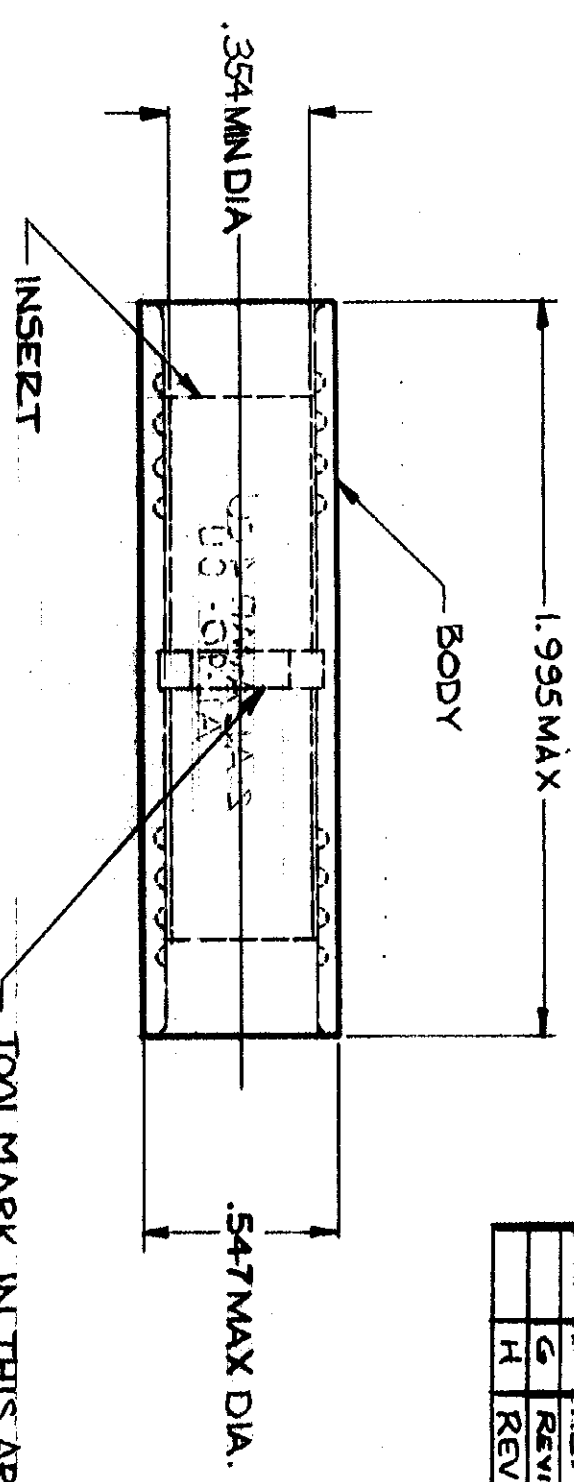
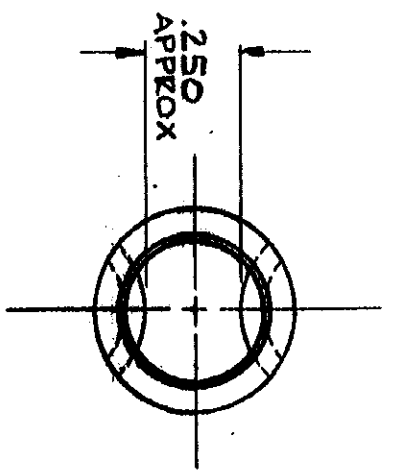

ZONE	LTR	REVISIONS DESCRIPTION	DATE	APPROVED
0		NPS 68-0306 (REV 1) <i>gms</i>	9-10-68	RHW
A		REV TITLE PER ECN PC-5545 <i>gms</i>	12-6-68	RHW
B		REV: 547 MAX DIA W/S 537 MAX DIA P-6002 <i>gms</i>	4-18-69	RHW
C		CHANGED 36970.354 PER ECN P-6105 <i>gms</i>	9-16-69	FCY
D		REVISED PER ECN P-6263 <i>gms</i>	1-8-70	FCY
E		REMOVED ENGINEERING CONT. P-6288 <i>gms</i>	4-17-70	FCY
F		REVISED PER ECN F-578 <i>gms</i>	1-11-72	<i>gms</i>
G		REVISED PER G-2072 <i>gms</i>	3-21-87	<i>gms</i>
H		REV PER G-5318 <i>gms</i>	10/25/89	WST

QTY	DESCRIPTION	PART NO.	MATERIAL # FINISH
1	WIRE SPLICE	52007	BODY: COPPER (QQ-C-576) TIN PL (MIL-T-10727) INSERT: BRASS (MIL-C-50) TIN PL (MIL-T-10727).0003MIN EXT THK.
MATERIAL # FINISH			

UNLESS OTHERWISE SPECIFIED DIM. ARE IN INCHES. TOLERANCES ON: DECIMALS ±.000 ANGLES ± 5° MATERIAL SEE TABLE	CONTRACT NO. B-3-68	DESIGN APPRO. <i>gms</i>	OTHER APPRO.
AMP INFO 5861	DATE TREAT #	FINISH SBE TABLE	

NAME	AMP INCORPORATED
ADDRESS	HARRISBURG, PENNSYLVANIA
SCALE	2:1
WT CALC	ACTUAL
SHEET	1 OF 1